

Montageanleitung Mounting instructions Instructions de montage

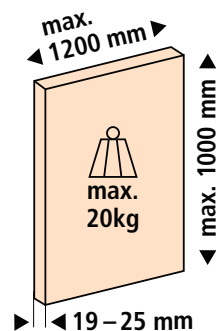

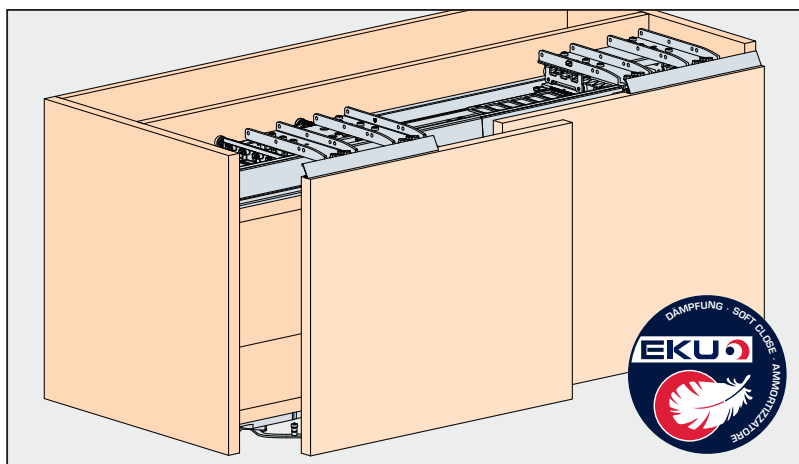



Schweizer Qualität - getestet nach EN 15706
Swiss Quality - tested in accordance with EN 15706
Qualité suisse - testée selon EN 15706

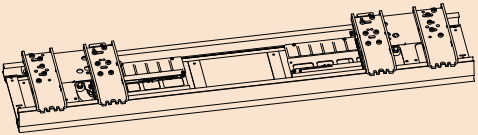
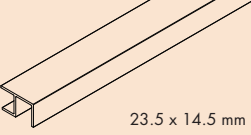
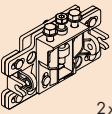
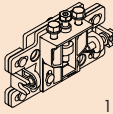
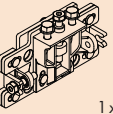

Garnituren/Sets/Guarniture

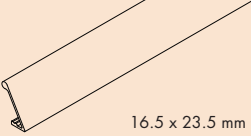
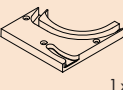
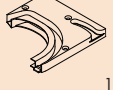
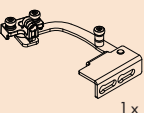
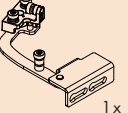
2 Türen Doors Ante	Typ S1 = KAM 1200-1399 mm 053.3390.071	Typ S4 = KAM 1800-1999 mm 053.3390.074
	Typ S2 = KAM 1400-1599 mm 053.3390.072	Typ S5 = KAM 2000-2199 mm 053.3390.075
	Typ S3 = KAM 1600-1799 mm 053.3390.073	Typ S6 = KAM 2200-2400 mm 053.3390.076

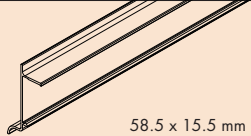
					1 x		23.5 x 14.5 mm
					2 x		16.5 x 23.5 mm
					2 x		58.5 x 15.5 mm

Abkürzungen/Abbreviations/Abbreviazioni

TH	Türhöhe	Door height	Altezza anta
TB	Türbreite	Door width	Larghezza anta
W	Position Führung	Guide position	Posizione guida
HF	Höhe Führung	Height of guide	Altezza guida
X	Bohrung Frontbefestigung	Drill hole front fixing	Foro fissaggio frontale
KP	Position Steuerkurve	Position radial cam	Posizione camma

Einbaugrößen/Installation dimensions/ Dimensioni di montaggio

		E	D
		mm	mm
Typ S1	= KAM 1200-1399 mm	231	97
Typ S2	= KAM 1400-1599 mm	281	147
Typ S3	= KAM 1600-1799 mm	331	197
Typ S4	= KAM 1800-1999 mm	381	247
Typ S5	= KAM 2000-2199 mm	431	297
Typ S6	= KAM 2200-2400 mm	481	347

In 4 Minuten fertig geplant und bestellbereit

Planned and ready for ordering in 4 minutes
Progettato e pronto per l'ordinazione in 4 minuti

www.eku.ch/planningtools



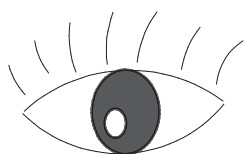
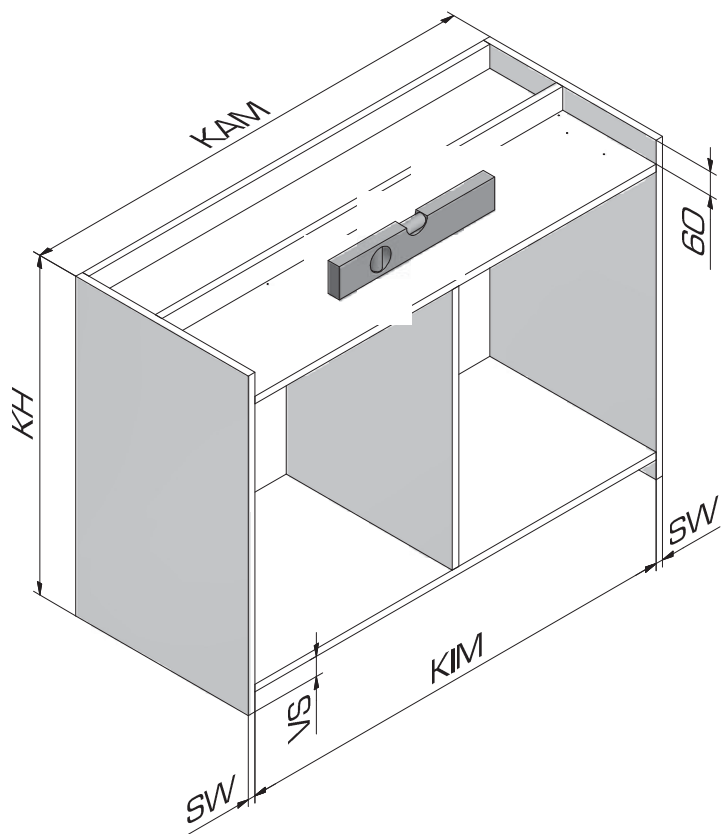

eku.ch/planungshilfen
eku.ch/planningtools
eku.ch/aidesalaplanification

Werkzeug | Tool | Outil

- PZ: 2
- SW: 4
- TX:
- No.:
- SW: 10

A

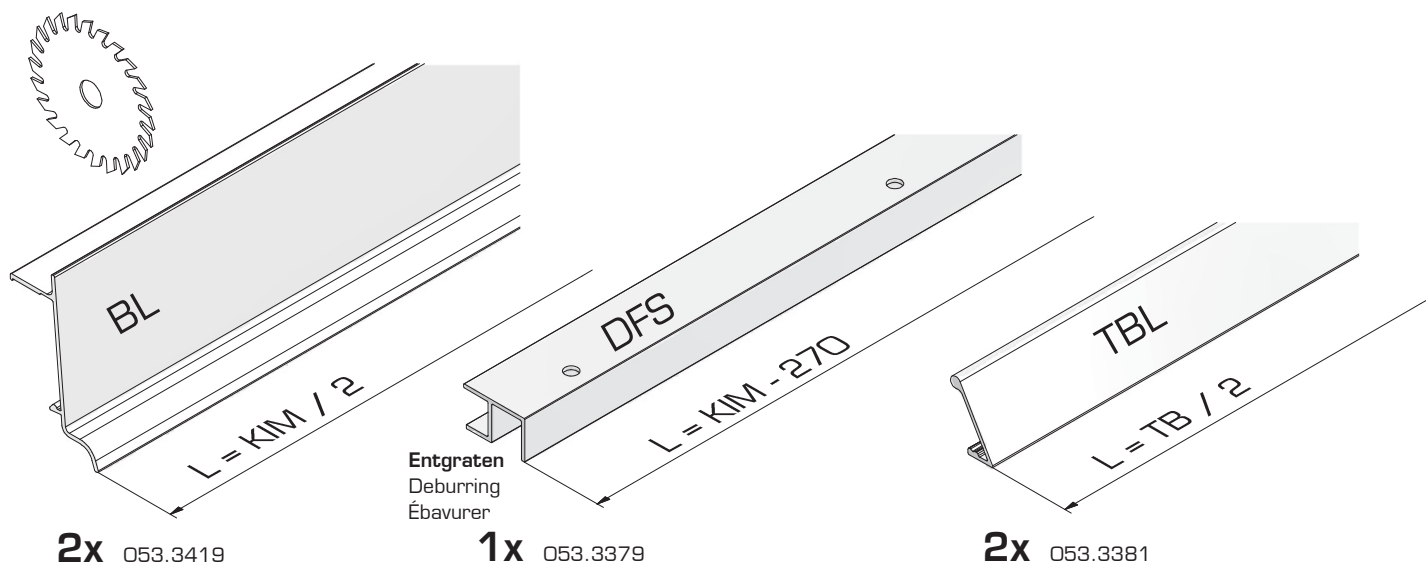

B Bearbeitung | Machining | Usinage

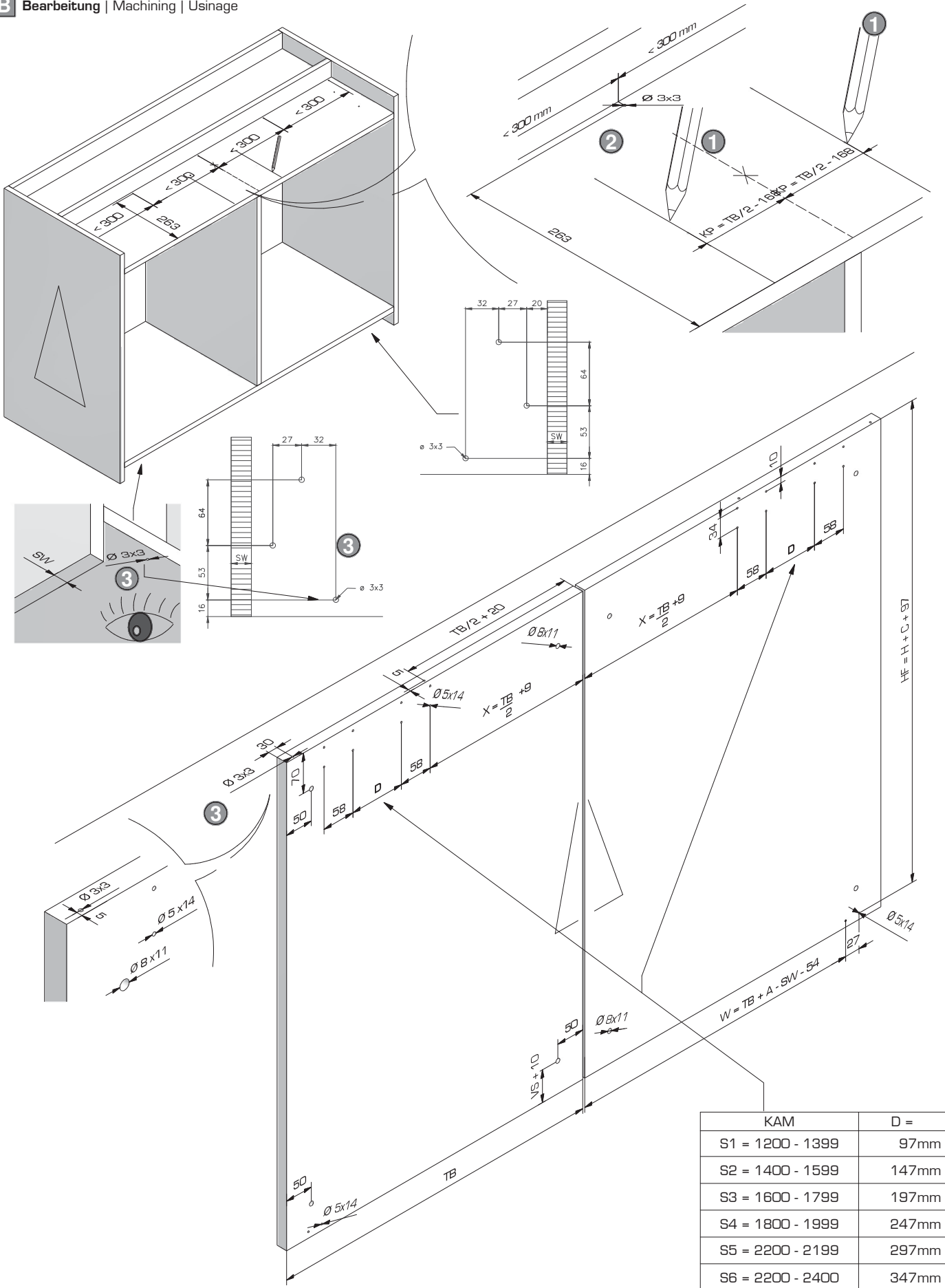

KAM	D =
S1 = 1200 - 1399	97mm
S2 = 1400 - 1599	147mm
S3 = 1600 - 1799	197mm
S4 = 1800 - 1999	247mm
S5 = 2200 - 2199	297mm
S6 = 2200 - 2400	347mm

C Sicherungsschraube entfernen | Remove security screw | Enlevez la ris de sécurité

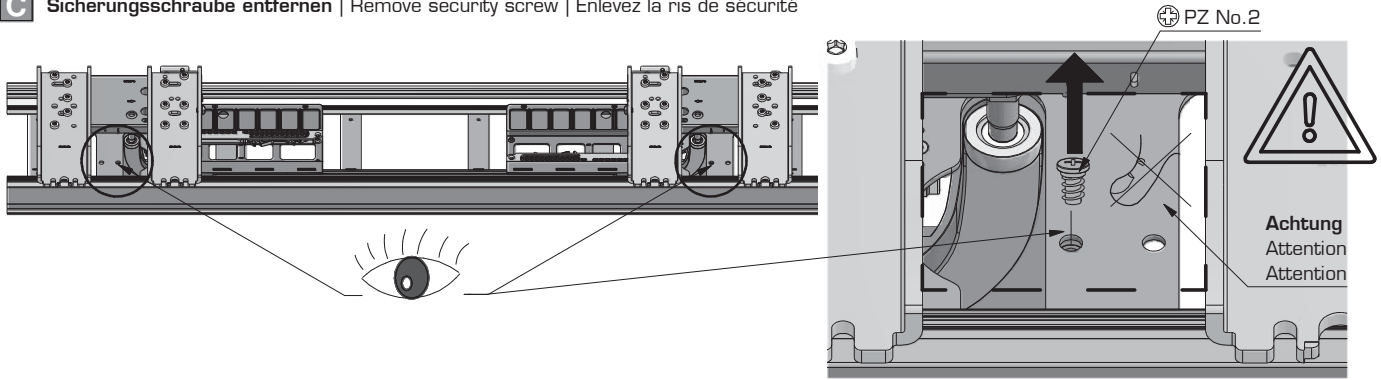

D

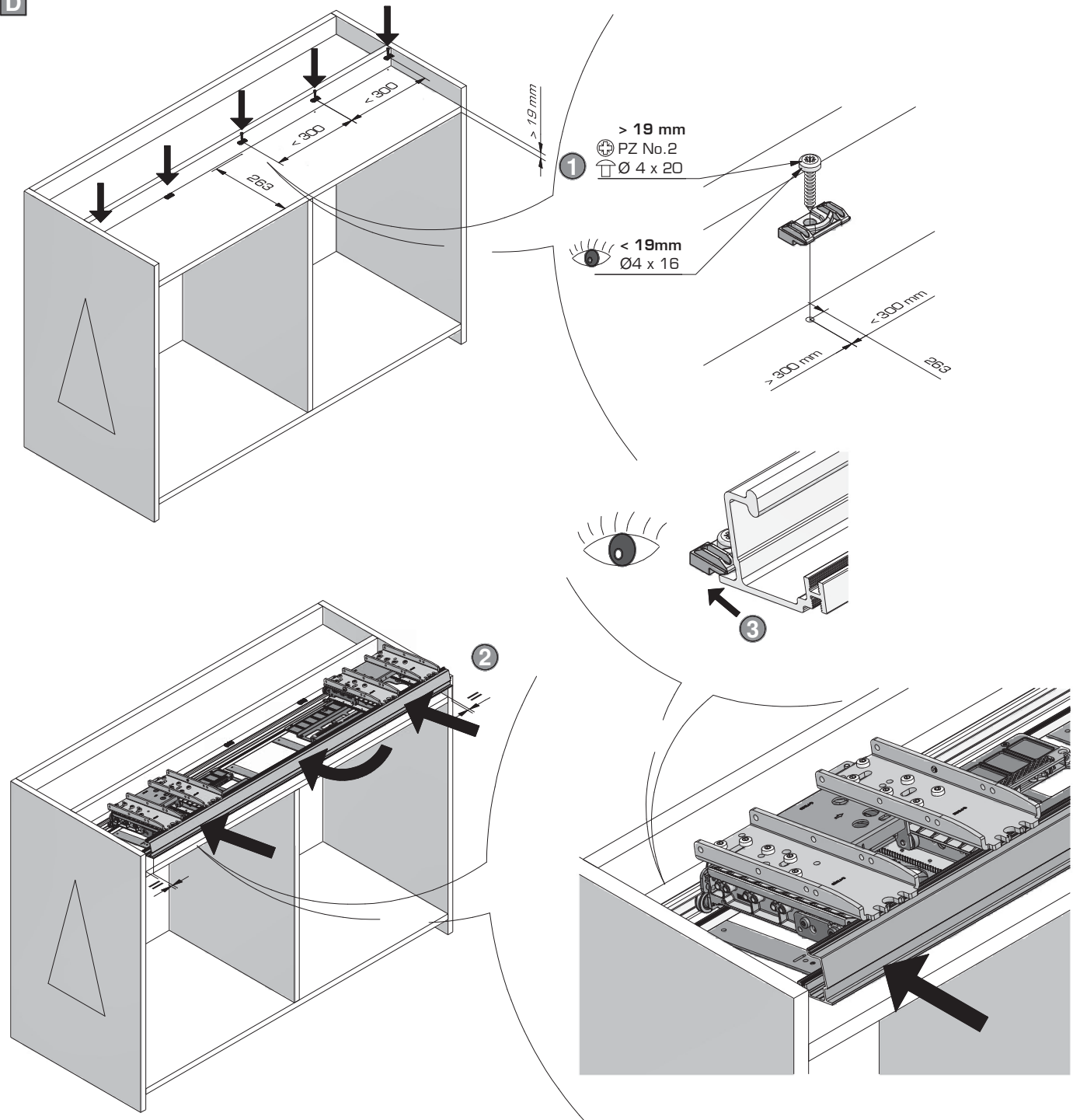

E

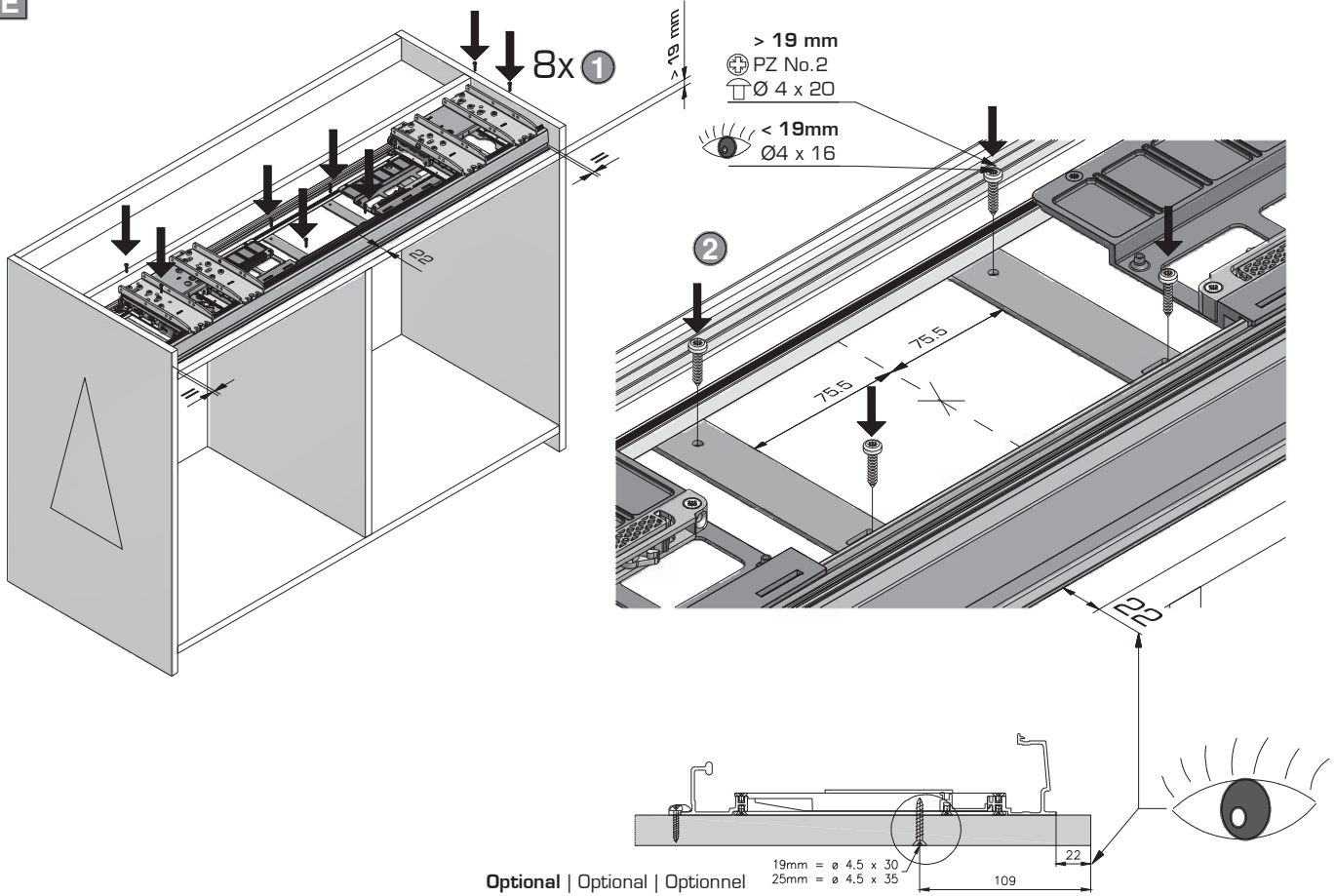

F

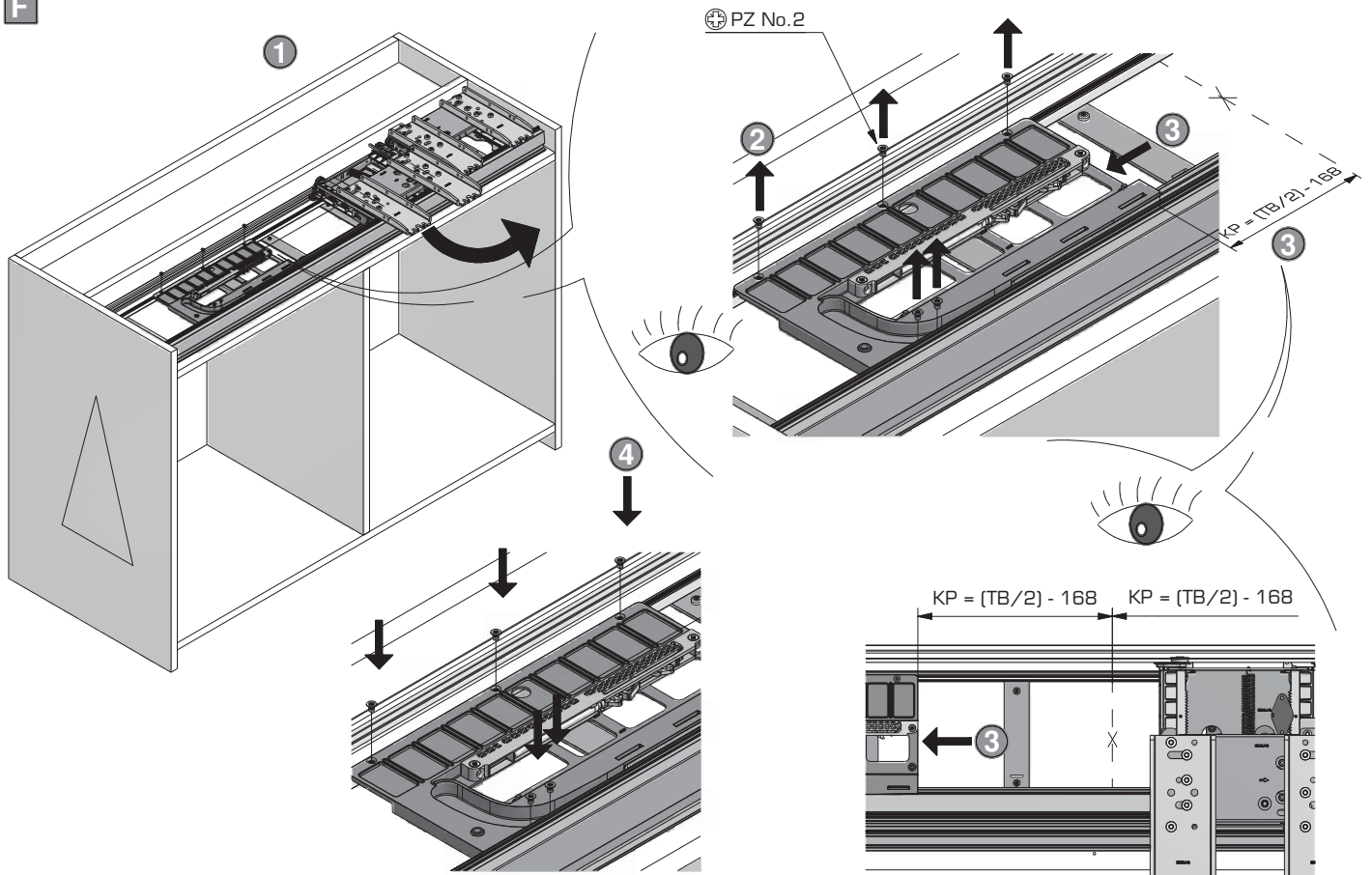

G Schienen reinigen! | Clean the tracks! | Nettoyez les rails!

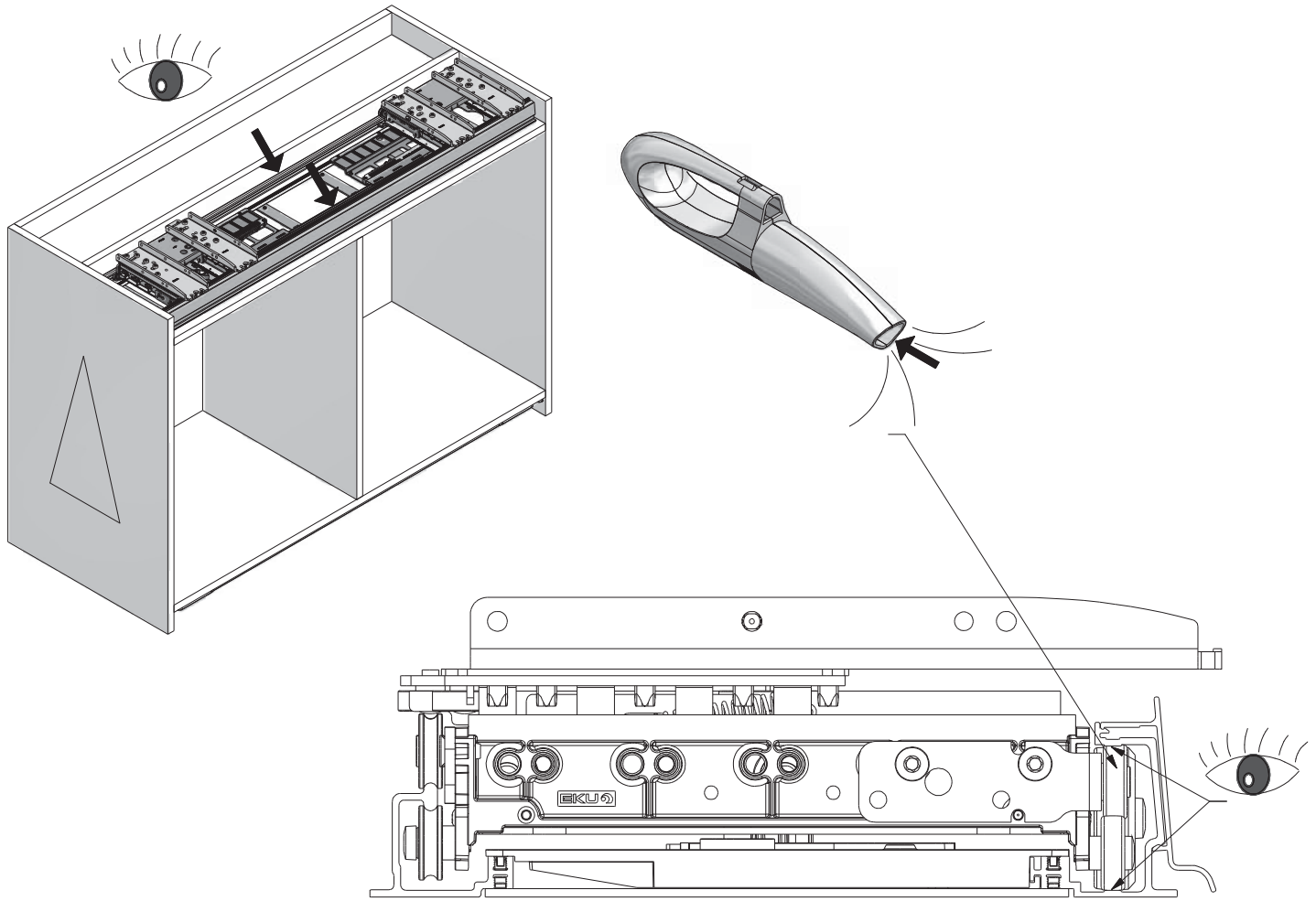

H

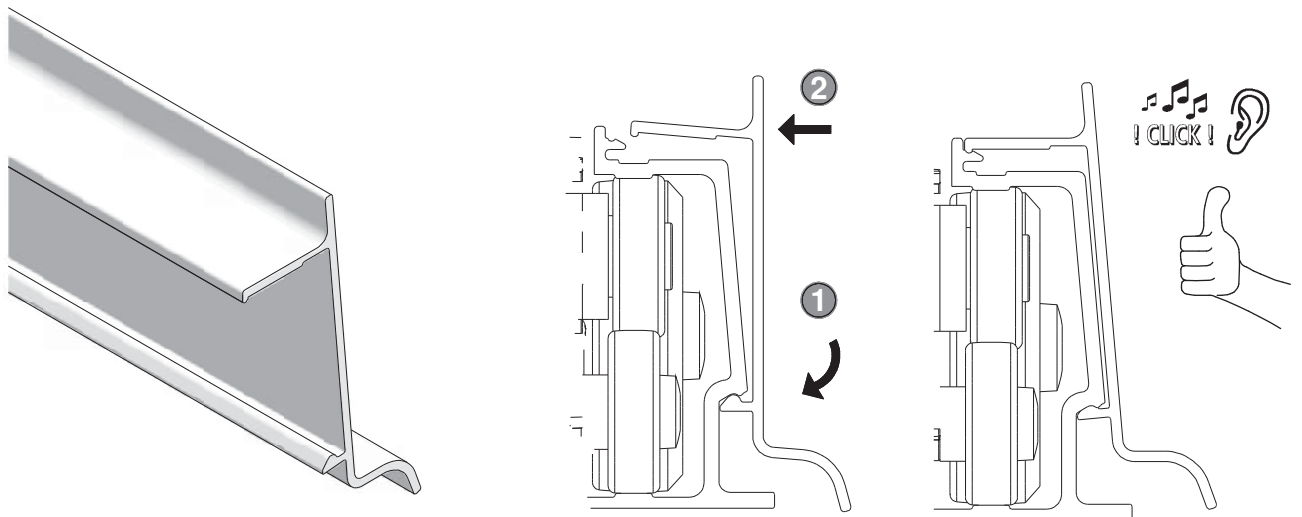

J

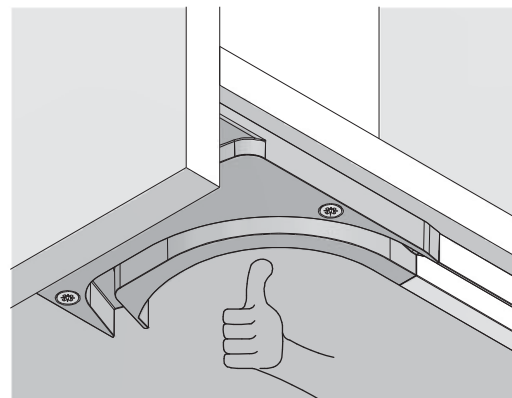
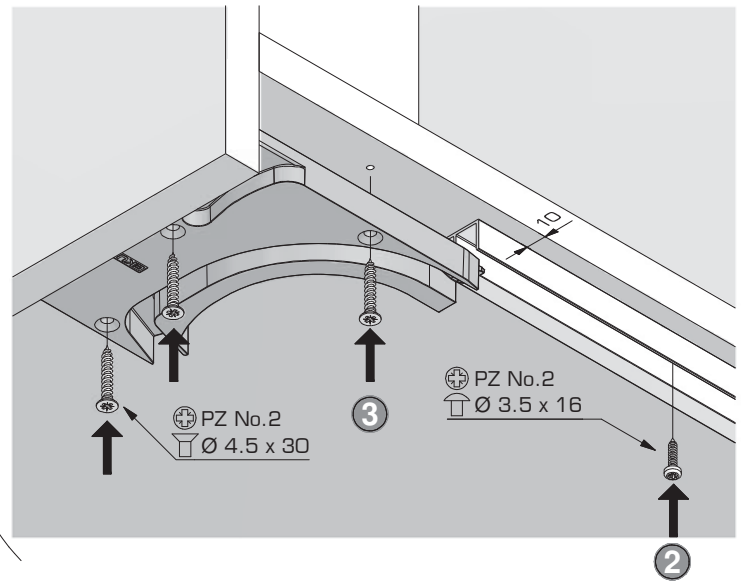
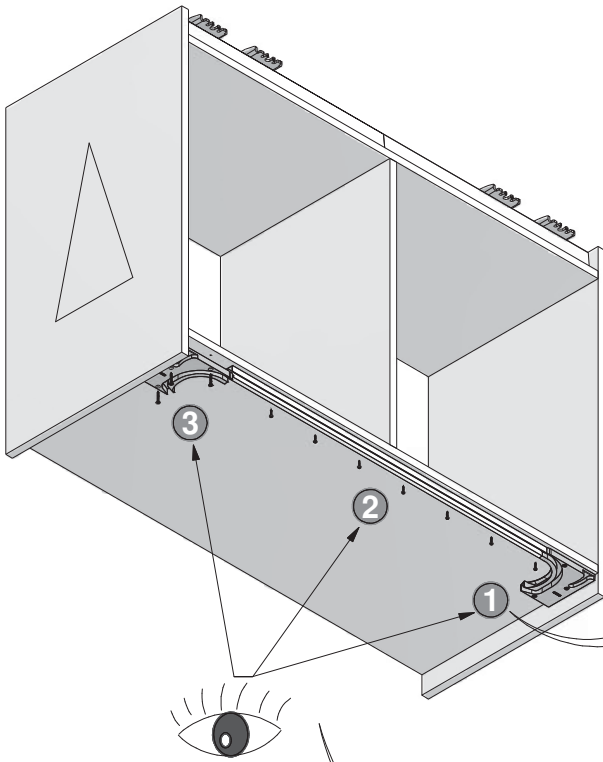
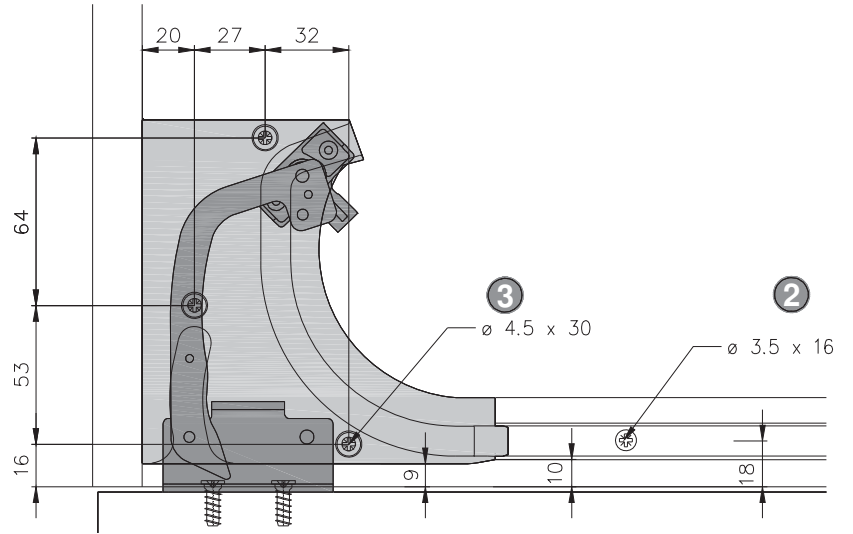

K

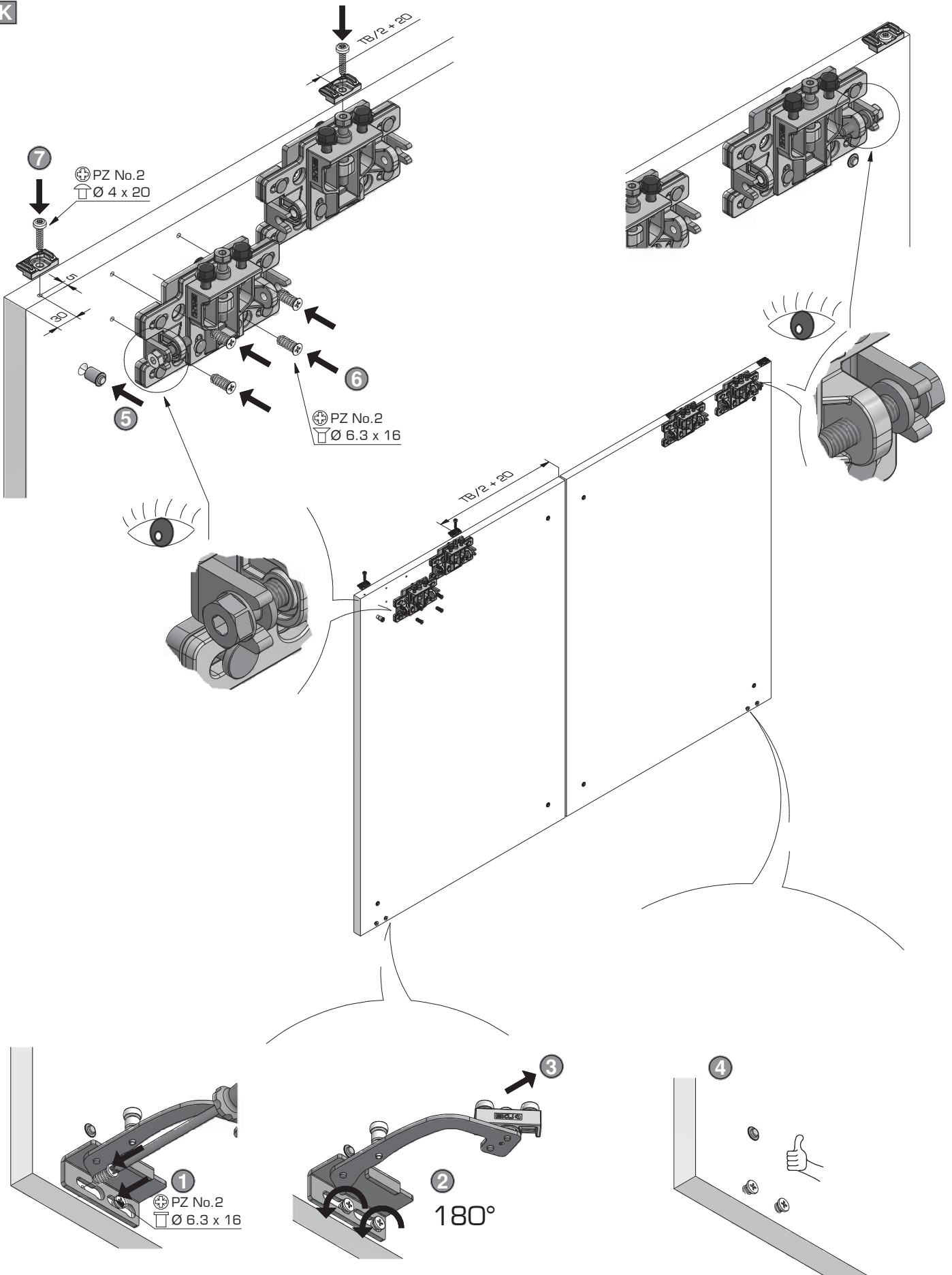

L Türe | Door | Porte

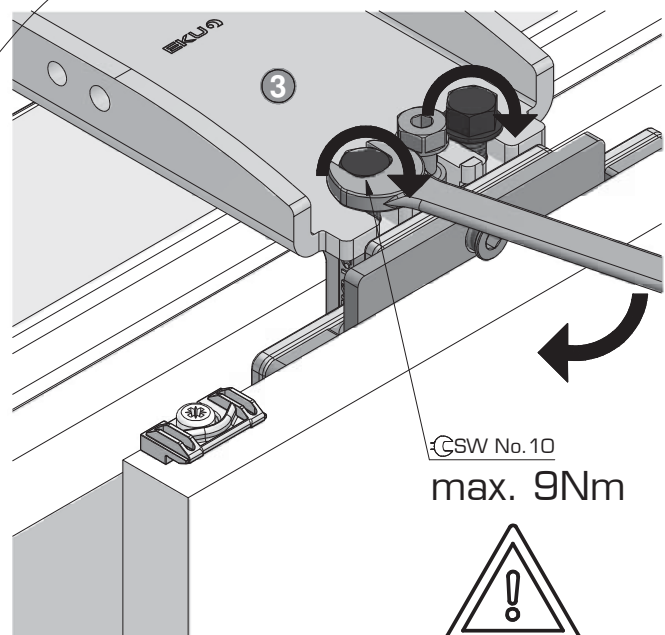
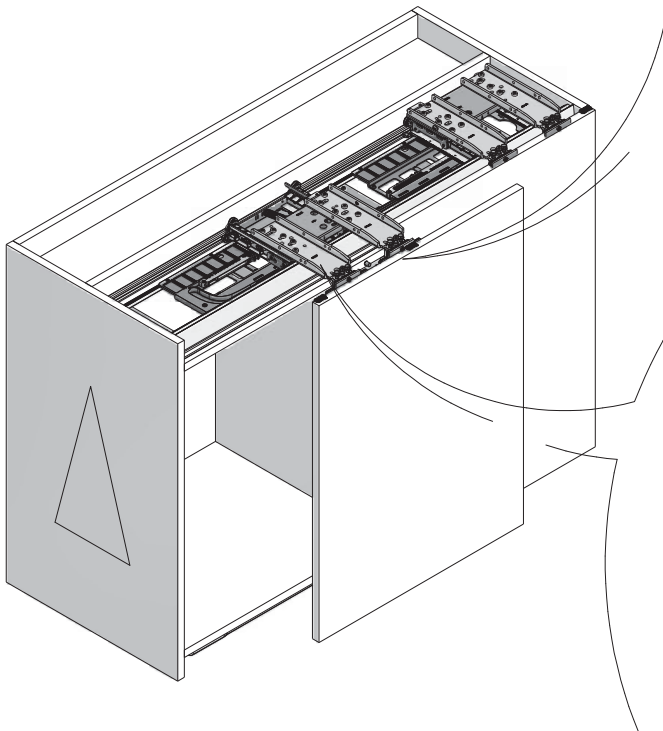
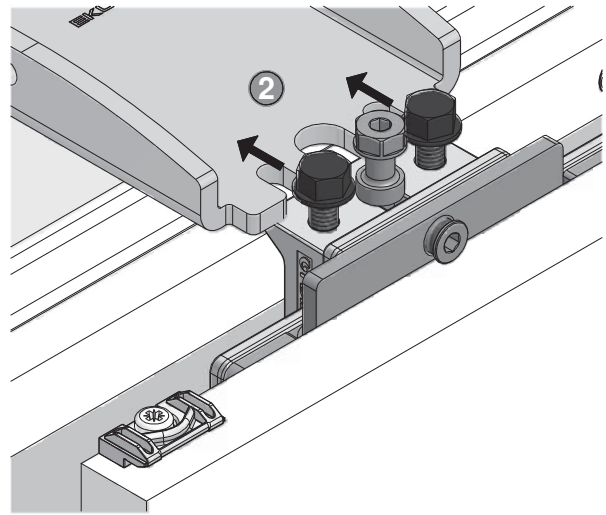
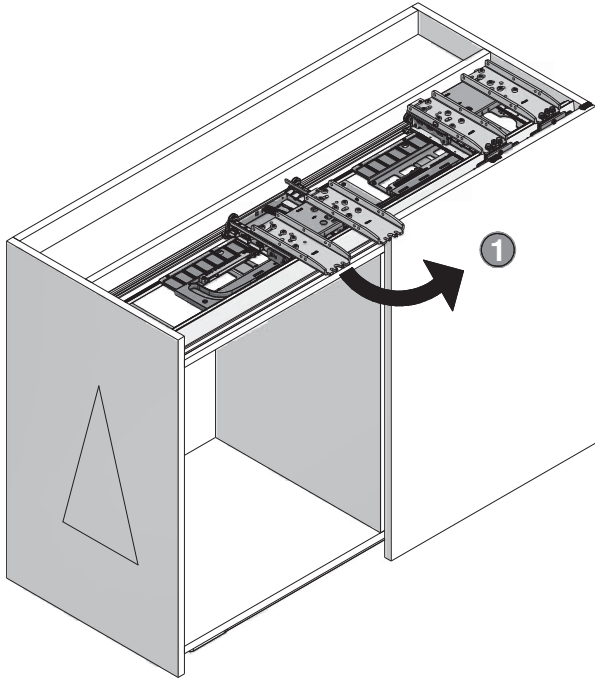

M Justieren | Adjust | Ajuster

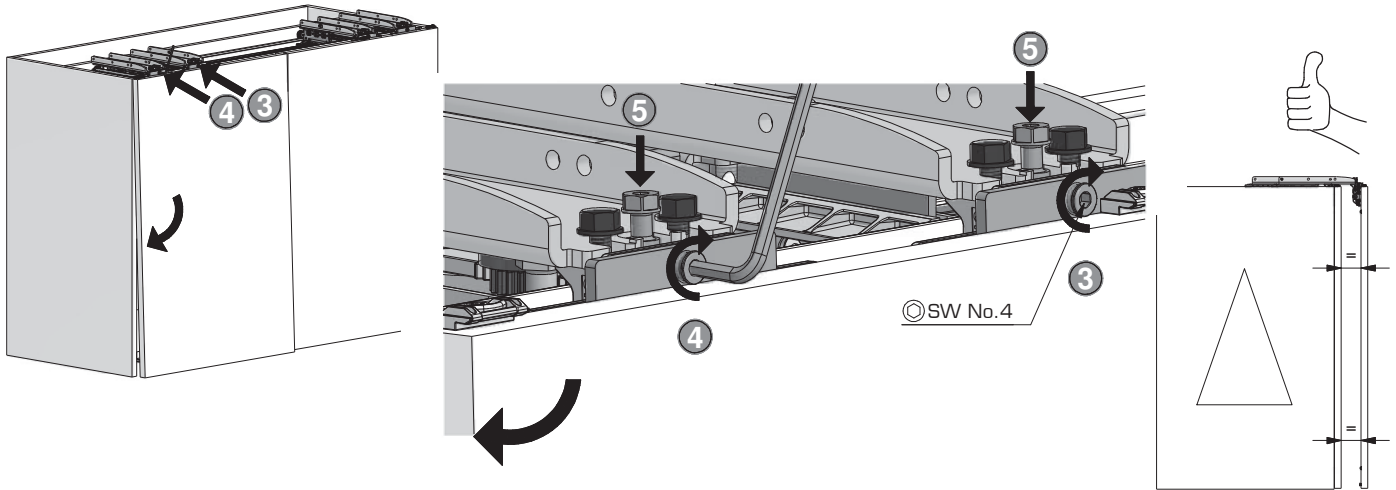
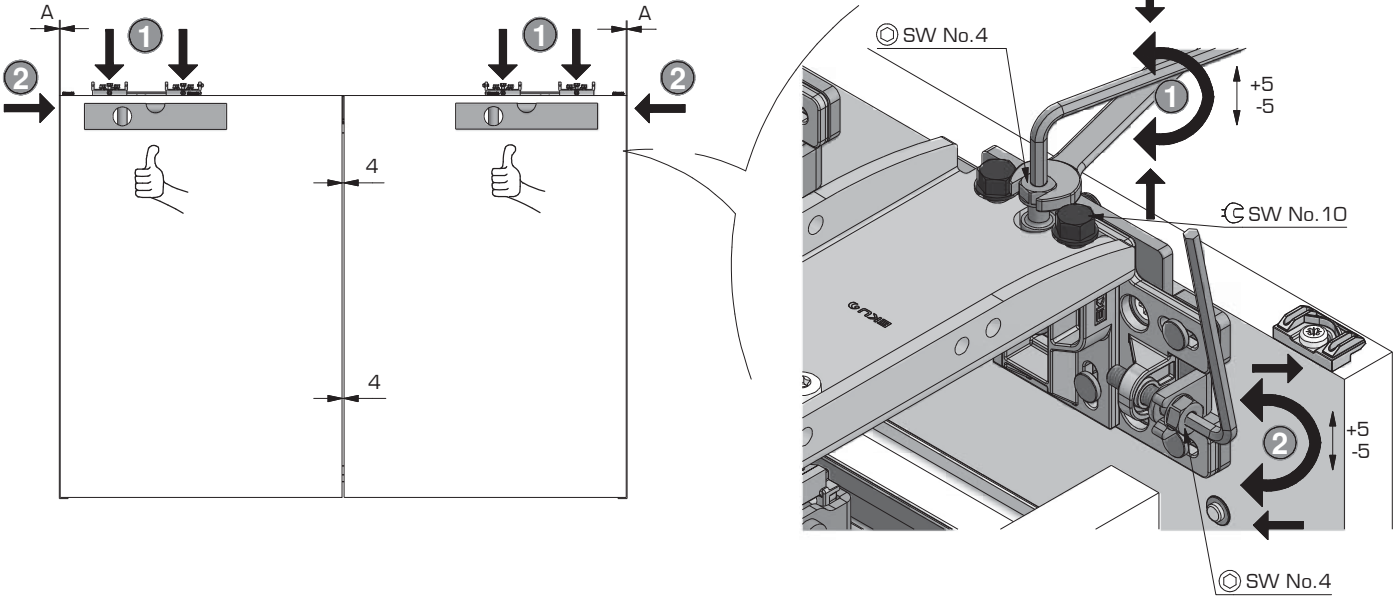

N

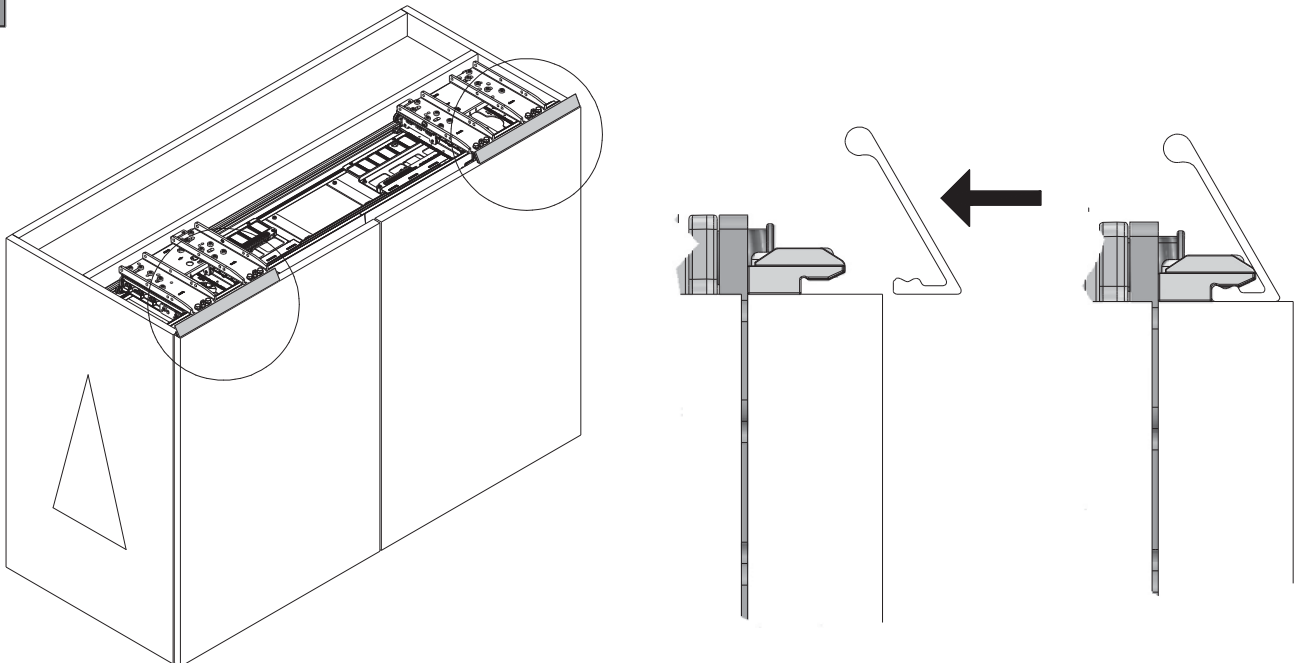

0

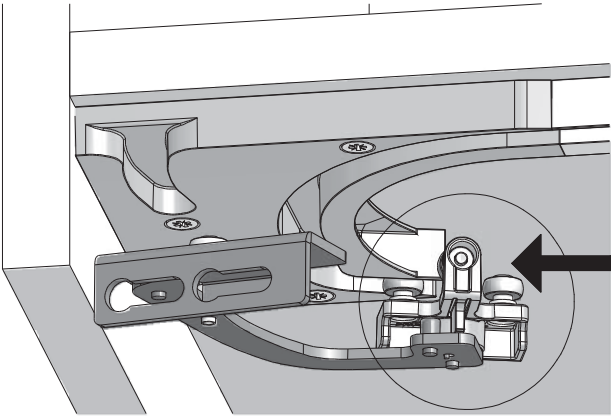

1

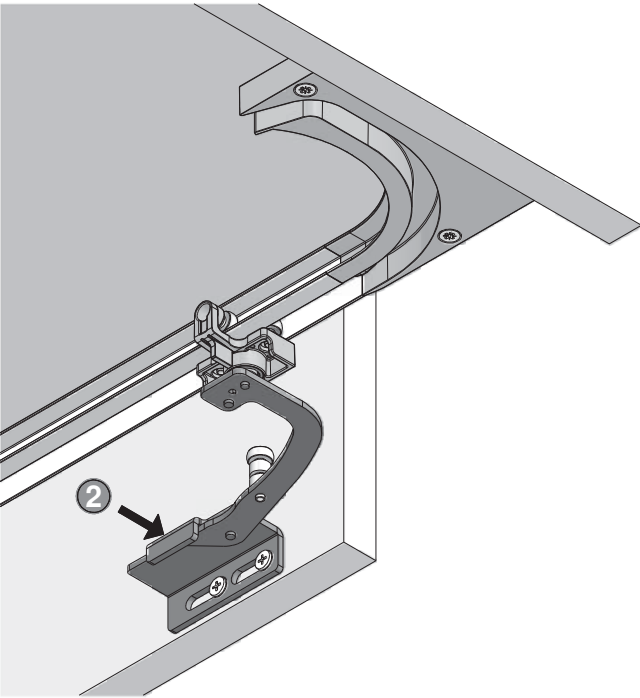
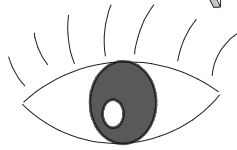
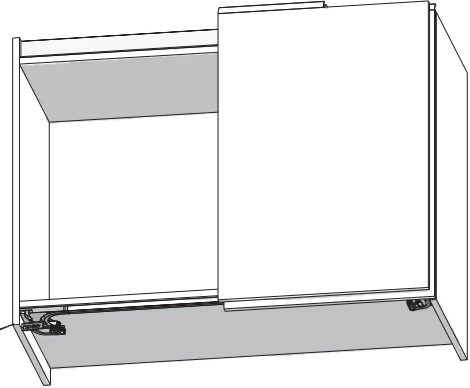

2

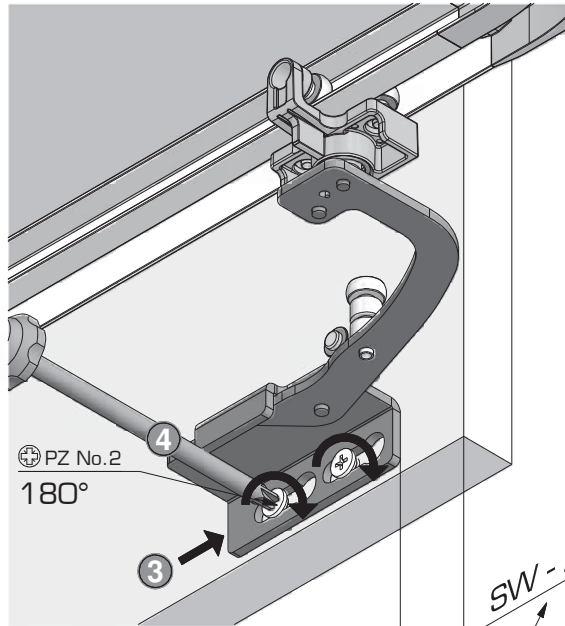

⊕ PZ No.2
180°

3

4

SW - A + 8

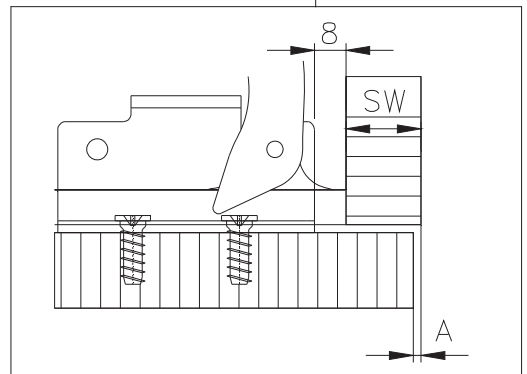
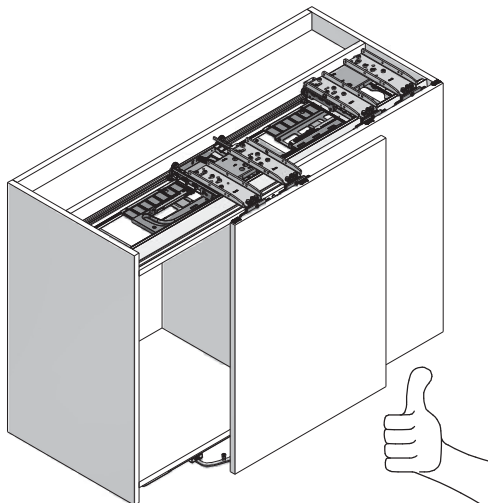
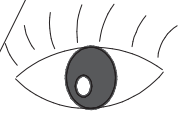

Einbaubeispiele / Mounting examples / Esempi di montaggio

